

4 DANCING DOLPHINS J32 · 3/4L

Barry Skelton: *The Dolphin Book* · Crib: *E-cribs* · Diagram: *Keith Rose's Diagrams*

- 1- 1c cross RH | cast off (2c up) ; turn LH 1¼ to face out and down on W side, 1M behind 1W (see note)
- 9- 2W+1c+3W Rsh lead-change Reel3 on W side (1W leads down, 1M up), at end face out and down on M side
- 17- 2M+1c+3M Lsh lead-change Reel3 on M side, 1c end in promhold facing W side
- 25- 1c pass Rsh round 3W, dance to top and cast to 2pl

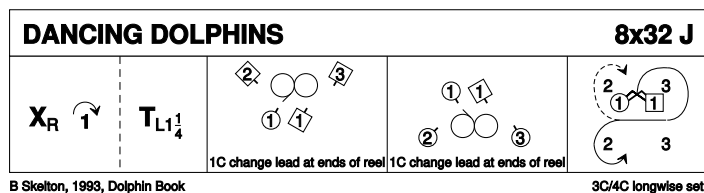

Note: during the reels 1M and 1W always cover parallel to the sidelines.

5 CULLA BAY S32 · 4S

Ann Dix: *RSCDS XLI 2* · Crib: *E-cribs* · Diagram: *Keith Rose's Diagrams*

- 1- 1c+3c turn RH ½ with person opposite, face that person | twirl R and into opposite place ; 2c+4c repeat this and face in **while**{4} 1c+3c (W leading) chase ¼ clw | curve into centre and swivel R to face out (1c facing 4pl and 3c facing 2pl)
- 9- Parallel Reels4 across
- 17- 2c+1c & 3c+4c circle4 L ; face other couple and set | ½ RHA, flowing into
- 25- 2c+4c LHA in the middle ; dance out passing same sex standing dancer on the side Rsh, and chase R (M leading) to 1pl/3pl (to 2,3,4,1).

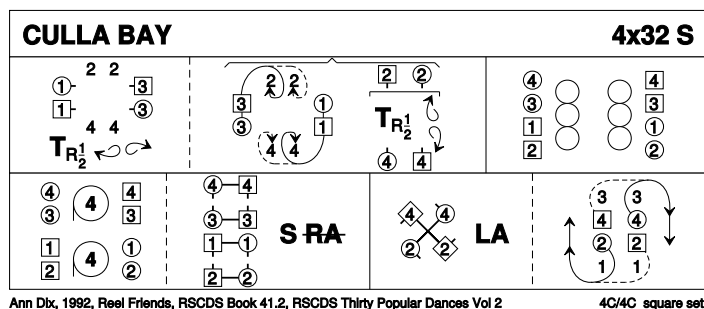

6 MAIRI'S WEDDING R40 · 3/4L

James B Cosh: *Twenty Two SCD* · Crib: *E-cribs* · Diagram: *Keith Rose's Diagrams*

- 1- 1c turn RH | cast (2c up) ; turn LH to face 1cnrs
- 9- 1c ½Reel4 with 1cnrs (pass P Lsh) ; Repeat with 2cnrs
- 17- Repeat with 3cnrs (1cnr person) ; Repeat with 4cnrs (2cnr person)
- 25- 1W+2c & 1M+3c Reels3 across, Lsh to 1cnr
- 33- 2c+1c+3c circle6 and back

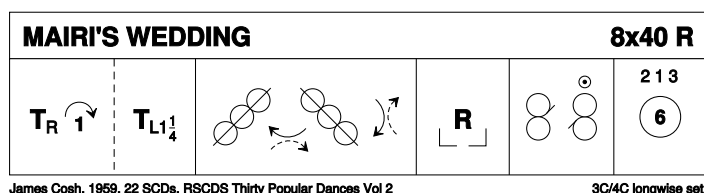

Note: Cosh explicitly tells 1c to pass Lsh in [9–24]; however the Rsh pass is quite common, and sometimes nicknamed “Mairi’s Divorce”.

7 BREAK

8 THE MACHINE WITHOUT HORSES J32 · 3/4L

David Rutherford: RSCDS XII 12 · Crib: E-cribs · Diagram: Keith Rose's Diagrams

- 1- 1c set | cast off (2c up) ; 1c+3c RHA
- 9- 1c set | cast up (2c down) ; 1c+2c LHA
- 17- 1c followed by 2c dance between 3c, cast up round them, dance up, 1c cast off to 2pl, **while** 2c dance into 1pl (no loops)
- 25- 2c+1c R&L

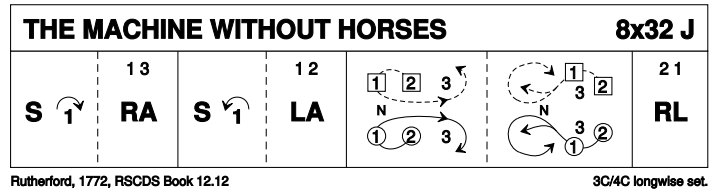

9 THE EXPERT DANCER S32 · 3/4L

Robert M Campbell: Farewell, My Fancy · Crib: MiniCribs · Diagram: Keith Rose's Diagrams

- 1-8 1s+2s dance the Bourrel:
1M+2L set advancing, 3/4 turn 2H & twirl to end BtoB (Lady facing up & Man down) **while** partners chase anticlockwise 1/2 way

Set to partners & turn 2H to own sides having changed places
- 9-16 1s cross down & cast up behind 3s, dance up between 2s & cast to face 2nd corners
- 17-24 1s set to 2nd corners & turn 2H pivoting right about to face 1st corners, set to 1st corners & turn 2H pivoting right about to 1L facing up between 2s & 1M facing down between 3s
- 25-32 1s dance RSh reels of 3 across & cross LH to 2nd place own side

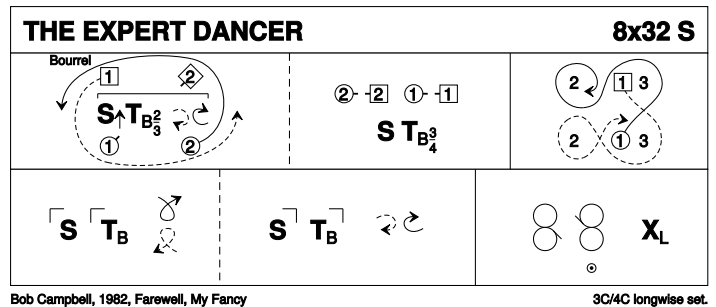

10 LIGHT AND AIRY J32 · 3/4L

William (18C) Campbell: RSCDS IV 5 · Crib: E-cribs · Diagram: Keith Rose's Diagrams

- 1- 1c set | cast off two (2c+3c up) ; 1c set | cast up two (2c+3c down)
- 9- 1c lead down the middle and up (1,2,3)
- 17- 1c+2c Allemande, to finish 1c facing 1cnrs
- 25- Turn CPCP to (2,1,3)

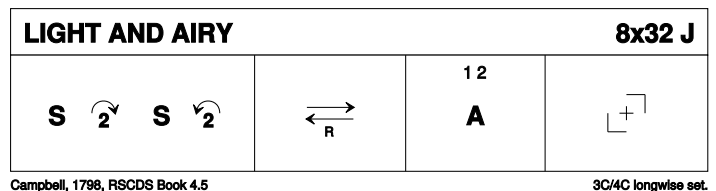

11 NORMA'S GARDEN R32 · 3/4L

Lydia Hedge: Spark O' Water · Crib: E-cribs · Diagram: Keith Rose's Diagrams

- 1- 1c dance to bottom into Mirror Fig8 (2c up on [7-8]) (2,1,3)
- 9- Diagonal R&L (3x,1,2x)
- 17- 3C S&Link twice (2,1x,3)
- 25- All set | 1c turn P RH 1½ | all set (2,1,3)

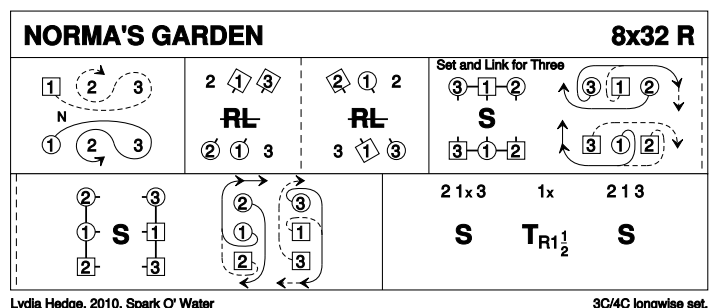

12 THE MINISTER ON THE LOCH S32 · 3/3L

Roy Goldring: Magazine Dances 2005-2009 · Crib: E-cribs · Diagram: Keith Rose's Diagrams

- 1- 1c+2c Poussette
- 9- 1c dance down 2 places, turn BH ;
dance up 2 places, turn BH, open
upwards and face out
- 17- 1c+3c DbIFig8 round 2c, 1c casting, 3c
crossing up to begin, 1c finish facing
out for
- 25- 1W+2W & 1M+2M turn EH 1½ ; 1c+3c repeat (2,3,1)

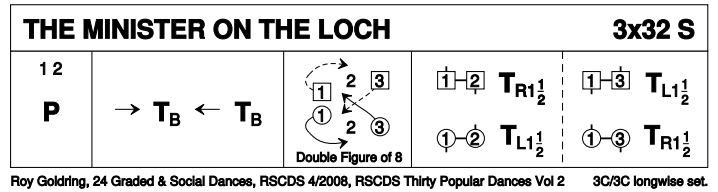

13 MAXWELL'S RANT R32 · 3/4L

David Rutherford: RSCDS XVIII 10 · Crib: E-cribs · Diagram: Keith Rose's Diagrams

- 1- Mirror Reels3 on the sidelines (1c
cross down) (1x,2,3)
- 9- 1c cross back into mirror Reels3 on
own sides
- 17- 1c cross RH | cast (2c up) ; ½ Fig8
round 2c
- 25- 1c dance down between 3c and cast up to 2pl ; 2c+1c+3c turn RH

